



LW001-BG PRO

Product Specification

Version 1.0

CONTENT

1 Product Brief	4
2 Application Scenarios.....	4
3 Product Specifications.....	5
3.1 Appearance and Mechanical Size	5
3.2 LED Indicators.....	5
3.3 General Specifications.....	7
4 User Guidance	7
4.1 How to install	7
4.2 How to disassemble LW001-BG PRO	8
4.3 How to power on/off LW001-BG PRO	9
4.4 How to connect to APP and configure parameters	10
5 General Function.....	10
5.1 Multiple Working Mode.....	10
5.1.1 Overview	10
5.1.2 Standby Mode.....	10
5.1.3 Timing Mode	11
5.1.4 Periodic Mode.....	11
5.1.5 Motion Mode	11
5.2 Auxiliary Operations.....	13
5.2.1 Overview	13
5.2.2 Downlink for Position.....	13
5.2.3 Vibration Detection.....	13
5.2.4 ManDown Detection.....	14
5.2.5 Active State Count.....	14
5.2.6 Tamper Alarm	14
5.3 Positioning Strategies.....	15
5.3.1 WiFi Fix	15
5.3.2 Bluetooth Fix	16
5.3.3 GPS Fix.....	17
5.3.4 Offline Fix	18
5.4 Bluetooth Broadcast Capabilities.....	18
5.4.1 Beacon Mode	18
5.4.2 Configuration Mode.....	18
5.4.3 Bluetooth Broadcast Contents.....	18
5.5 LoRaWAN Capabilities.....	20
5.5.1 Timed Reconnect	20
5.5.2 LoRa Uplink Transmission Strategy.....	20
5.6 3-Axis Accelerometer Capabilities	20
5.7 Local Data Sync	21
5.8 Battery Performance.....	21
5.8.1 Low battery Alert	21
5.8.1 Shutdown message reminder	21
5.9 Time Synchronization.....	21
5.10 Default Power Status	22
5.11 Configuration Tool	22
6 Uplink Payload.....	22

6.1 Common payload header.....	22
6.2 Heartbeat Payload	23
6.3 Location Payload	24
6.3.1 Location Fixed Payload.....	24
6.3.2 Location Failure Payload	25
6.4 Shutdown Payload	26
6.5 Vibration Payload.....	27
6.6 Man Down detection Payload.....	27
6.7 Tamper Alarm Payload.....	27
6.8 Event message payload.....	27
6.9 Battery Consumption Payload	28
7 Maintenance instruction.....	28
8 Revision History.....	29

1 Product Brief

LW001-BG PRO is a wireless smart, ultra-low power consumption, indoor&outdoor LoRaWAN Tracker. It integrates GPS positioning, Bluetooth positioning and WiFi positioning, supports a variety of working modes, suitable for most tracking applications. It supports ABP and OTAA two different network access mode, and easy to configure and update firmware by MKLoRa APP.

Ideal to optimize logistic process, asset management, warehouse and inventory scenarios, outdoor tracking, theft protection, livestock tracking and much more.

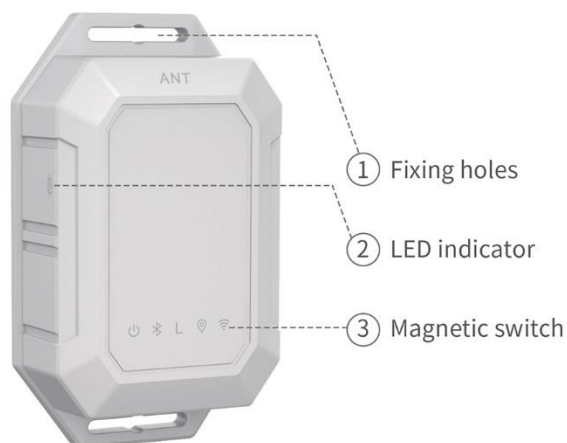

2 Application Scenarios



Scenario 1: Heavy Equipment Tracking

LW001-BG PRO can be used for real-time tracking of heavy equipment (vehicles, machines, and other outdoor facilities), or can be used to monitor heavy equipment based on its movement status

Scenario 2: Container Tracking

The LW001-BG PRO can be used to track the location of containers in real time by fixing it on the container, which is suitable for container tracking and management in terminal and port scenarios.





Scenario 3: Livestock Tracking

The LW001-BG supports strap mounting, which allows the LW001-BG PRO to be mounted on the neck of livestock via a strap. By acquiring the livestock location information, it enables intelligent grazing management.

Scenario 4: Industrial Asset Tracking

The LW001-BG PRO is ideal for tracking, monitoring and anti-theft protection of critical industrial assets due to its motion-triggered location and anti-tamper alarm features.



3 Product Specifications

3.1 Appearance and Mechanical Size

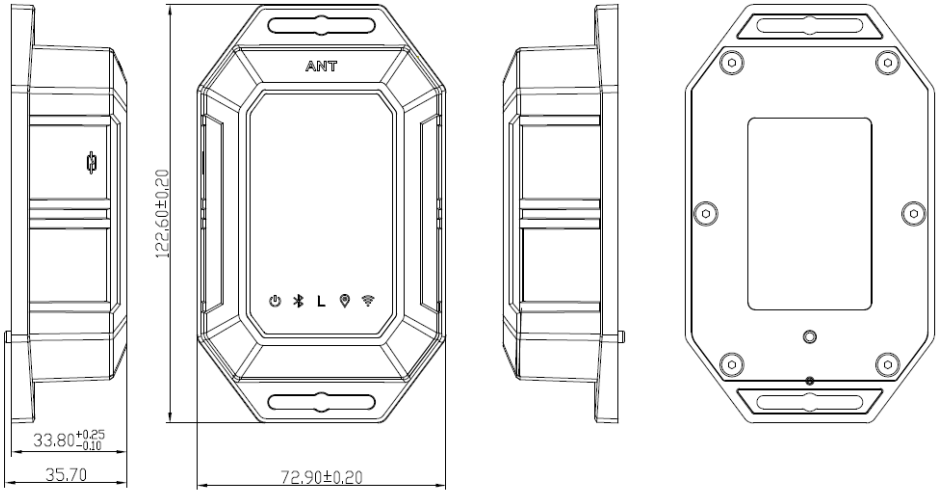

3.2 LED Indicators

Indicators	Items	Indicator	Operation
------------	-------	-----------	-----------

Power Indicators	Turn ON	Solid Green and keep 3S	Approach and quickly move away from the Hall sensor area with a magnet 3 times (Each approach needs to be held for about 0.5s at least)
	Turn OFF	Green LED blink 3S	Approach and quickly move away from the Hall sensor area with a magnet 3 times (Each approach needs to be held for about 0.5s at least)
	Low battery	Green LED blink once every 10s	The device is in Low battery.
LoRa Indicators	Join LoRa Network	Solid white and keep 3S	If the device had never Joined any network, after turning on, the device will automatically send join request
Bluetooth Indicators	Bluetooth connection established successfully	Solid Blue	Connect to the device via APP successfully
	In Bluetooth positioning	Blue LED slow blink	The device is in Bluetooth fix
	Bluetooth positioning successfully	Solid blue and keep 2S	
	Bluetooth positioning failure	Blue LED blink 2S	
	Firmware Upgrade	Blue LED slow blink during the upgrade/Solid Blue and keep 2S after upgrade successfully / Blue LED blink 2S after upgrade failed	Firmware upgrade via OTA in DFU mode
GPS Indicators	In GPS positioning	Blue LED slow blink	
	GPS positioning successfully	Solid blue and keep 2S	
	GPS positioning failure	Blue LED blink 2S	
WIFI Indicators	In WIFI positioning	Blue LED slow blink	
	WIFI positioning successfully	Solid blue and keep 2S	
	WIFI positioning	Blue LED blink 2S	

	failure		
All Indicators	All LED slow blink	Tamper alarm indication	Tamper alarm is triggered

3.3 General Specifications

Categories	Parameter	Value
LoRa Wireless Specification	LoRa Protocol	LoRaWAN V1.0.3
	Lora Frequency	EU868/AU915/US915/AS923/IN865/KR920/EU433/CN470/CN779/RU864
	Tx Power	Max 20dBm
	Sensitivity	-137dBm@SF12 300bps
	LoRa Communication Distance	Up to 6 km (in urban open space)
BLE Wireless Specification	Bluetooth® (BLE)	V4.2
	TX Power	Max 8 dBm
	BLE Communication Distance	Up to 50m in free space
Physical Parameter	Dimension	122mm×72mm×33mm (±2mm)
	Shell Material	ASA+PC
Power Consumption	Power Supply	6500mAH available (7800mAH no-chargeable battery)
	Operating Current	< 180mA
	Sleep Current	< 15uA
Application Parameter	Operating Temperature	-20 ~ + 60°C
	Operating Humidity	5%-95% (No condensation)
	IP Rating	IP67
	Certification	CE FCC certification in process

4 User Guidance

4.1 How to install

Multiple installation options of LW001-BG PRO like hanging with screws, double-sided sticker, tape or DIN rail can be selected by user. After deployment, LW001-BG PRO can be easily

LW001-BG PRO

powered on by a magnet via integrated omni polar Hall-effect sensor and it can avoid accidental control by an external button.

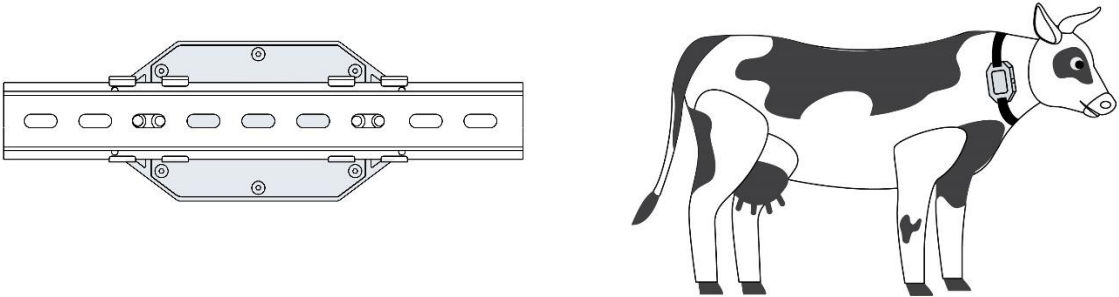
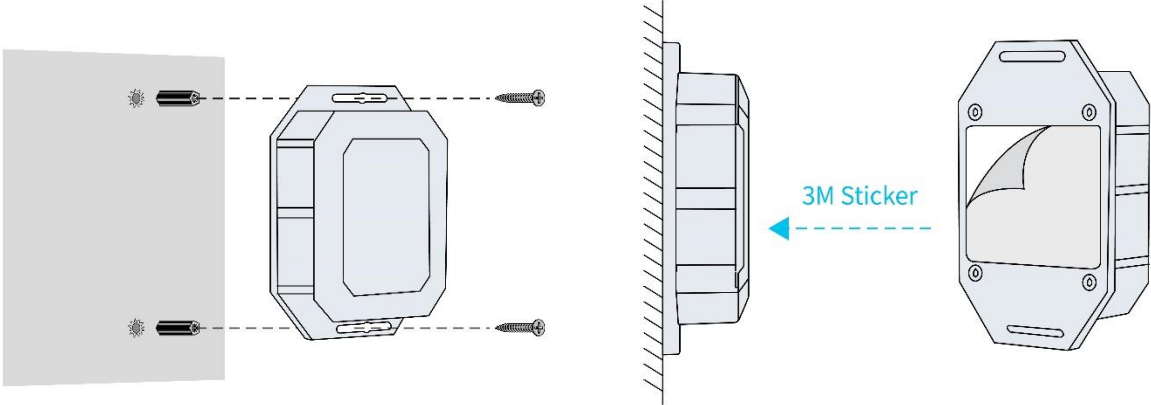

4.2 How to disassemble LW001-BG PRO

Disassemble flow:

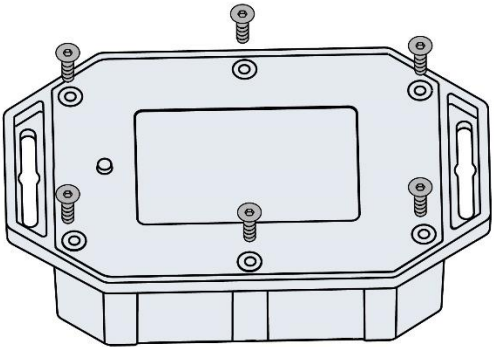

Step1: Remove the screws on the bottom of the device

Step2: Remove the back cover

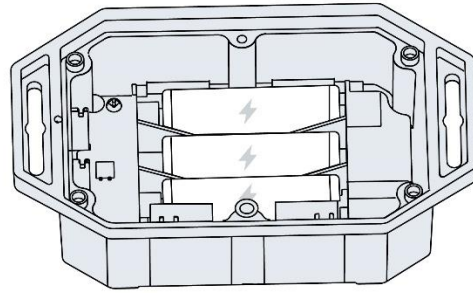

4.3 How to power on/off LW001-BG PRO

There is one way to power on LW001-BG PRO.

Magnetic switch:

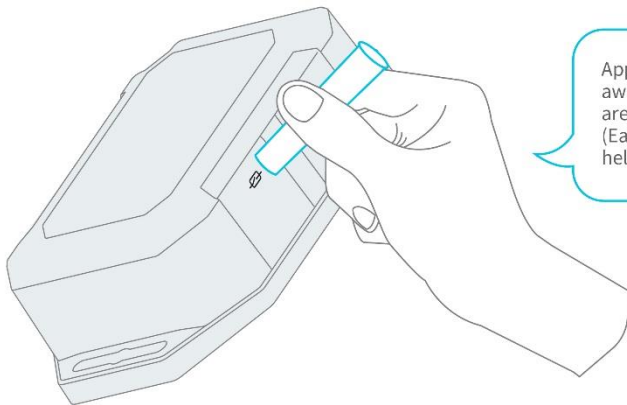

Approach and quickly move away from the Hall sensor area with a magnet 3 times (Each approach needs to be held for about 0.5s at least)

There are three way to power off LW001-BG PRO

1. Magnetic switch:

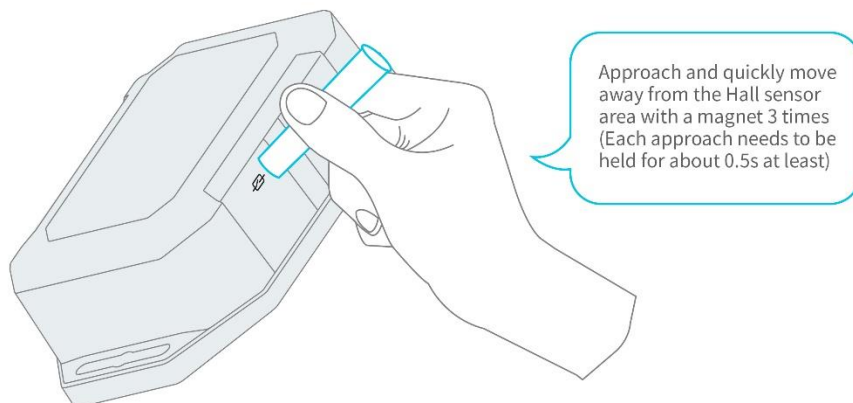

2. Turn off the device via MKLoRa APP
3. Turn off the device via LoRa Downlink Command

4.4 How to connect to APP and configure parameters

Please download “MKLoRa” APP from app store directly. For more configuration details, please refer to document - “LW001-BG PRO User Manual”.

5 General Function

5.1 Multiple Working Mode

5.1.1 Overview

LW001-BG PRO supports four different working modes: *Standby Mode*, *Timing Mode*, *Periodic Mode* and *Motion Mode*.

LW001-BG PRO can only be in one mode at the same time, and the user can use the mobile app or LoRa downlink command to switch the working mode.

No matter what mode the device is, *Heartbeat Payload* will be sent according to *Heartbeat Interval* (The *Heartbeat interval* can be set by user). If other uplink payload is sent during the *Heartbeat Interval*, the *Heartbeat Interval* will be recalculated with the uplink time point of that payload.

Along to the main working mode, LW001-BG PRO can perform extra operations known as *Auxiliary Operations*.

5.1.2 Standby Mode

In *Standby Mode*, the device will only report *Heartbeat Payload* according to *Heartbeat Interval* and will not send the *Location Payload* which includes LW001-BG PRO’s positions.

If location information is needed in *Standby Mode*, user can use *Downlink for Position* (one of *Auxiliary Operations*) to get the *location payload*.

In additional, the user can also enable other auxiliary operations to achieve the corresponding functions. (*Refer to 5.2 Auxiliary Operations*)

5.1.3 Timing Mode

In *Timing Mode*, LW001-BG PRO will report *Location Payload* at the time point configured in advance. Each LW001-BG PRO can set up to 10 reporting time points.

We divided the day into 96 time points, each 15 minutes apart, with the first time point being 00:00. Each LW001-BG PRO can set up to 10 reporting time points.

User can select different *Positioning Strategies* for *Timing Mode* to obtain location information according to different application scenarios.

User also can use *Downlink for Position* (one of *Auxiliary Operations*) to get the extra *location payload*.

In additional, the user can also enable other auxiliary operations to achieve the corresponding functions. (*Refer to 5.2 Auxiliary Operations*)

5.1.4 Periodic Mode

In *Periodic Mode*, LW001-BG PRO will report its positions periodically. The report interval can be set by user.

User can select different *Positioning Strategies* for *Periodic Mode* to obtain location information according to different application scenarios.

User also can use *Downlink for Position* (one of *Auxiliary Operations*) to get the extra *location payload*.

In additional, the user can also enable other auxiliary operations to achieve the corresponding functions. (*Refer to 5.2 Auxiliary Operations*)

5.1.5 Motion Mode

When the LW001-BG PRO is in motion mode, it can monitor the whole process of the LW001-BG PRO from stationary to motion and from motion to stationary through the built-in 3-axis accelerometer sensor.

The whole motion process can be divided into four parts: *Start of movement*, *In movement*, *End of movement*, *Stationary*.

5.1.5.1 Start of movement

LW001-BG detects whether the device is moving by 3-axis accelerometer sensor, and if the preset moving judgment condition (*Motion Threshold* & *Motion Duration*) is reached, the device is considered to start moving and start positioning.

When the positioning process is finished, LW001-BG PRO will send *Location Payload*. User can choose to send this payload repeatedly. The number of repetitions can be set by user.

User can select different *Positioning Strategies* for *start of movement* to obtain location information according to different application scenarios.

Note: User can choose whether to report Location Payload or not at start of movement.

5.1.5.2 In movement

After *start of movement*, LW001-BG PRO will be *in movement* state.

LW001-BG PRO will send *Location Payload* periodically during the movement.

User can select different *Positioning Strategies* for *in movement* to obtain location information according to different application scenarios.

Note: User can choose whether to report Location Payload or not in movement.

5.1.5.3 End of movement

The LW001-BG detects whether the device is still moving by 3-axis accelerometer sensor. If the device never reaches the movement trigger condition within N seconds, the device is considered to have stopped moving and started positioning immediately. When the positioning process is finished, LW001-BG PRO will send 1st *Location Payload*.

LW001-BG PRO can report multiple different *Location Payloads*, the number of *Location Payloads* and the interval between *Location Payloads* can be set by user.

User can select different *Positioning Strategies* for *End of movement* to obtain location information according to different application scenarios.

Note: User can choose whether to report Location Payload or not at End of movement.

5.1.5.4 Stationary

After the last *Location Payload* of *End of movement* was sent, the device will come into *Stationary* state.

When the device is in *Stationary state*. The device will only report *Heartbeat Payload* according to *Heartbeat Interval* and will not send the *Location Payload*.

5.1.5.5 Event Message

Event messages are notifications sent by LW001-BG PRO to inform the server about a specific event when the device is in *Motion Mode*.

There are three types of event message notifications that can be activated:

Event message at *start of movement*: Event message will be sent when the preset moving trigger condition (*Motion Threshold & Motion Duration*) is reached.

Event message *During the movement*: When the device is *in movement*, Event messages will be sent whenever the device starts positioning.

Event message at *End of movement*: Event message will be sent when the device come into *End of movement* state.

Note: *All the above three events can be set individually to send or not to send event messages*

5.2 Auxiliary Operations

5.2.1 Overview

Whatever the working mode, the LW001-BG PRO supports *Auxiliary Operations*, which can be:

- Downlink for Position
- Vibration Detection
- ManDown Detection
- Active State Count
- Tamper Alarm

Notes: All Auxiliary Operations can be accrued.

5.2.2 Downlink for Position

When the Downlink for Position is used, LW001-BG PRO's position can be requested via LoRa downlink command. (*Refer to Document "LW001-BG PRO Downlink Command Document"*)

User can select different *Positioning Strategies* for *Periodic Mode* to obtain location information according to different application scenarios.

5.2.3 Vibration Detection

When the LW001-BG PRO is used for asset tracking, the built-in three-axis sensor detects whether the asset has been hit or treated violently. If the set vibration judgment condition (*Vibration Threshold*) are met, *Vibration Detection Payload* will be reported to the server and inform the user.



5.2.4 ManDown Detection

When the LW001-BG PRO is used to track large machinery and equipment or livestock, the LW001-BG PRO's built-in three-axis sensor can detect whether the equipment or livestock being tracked is stationary for a long time.

If the preset ManDown detection condition is reached, LW001-BG PRO will report the *ManDown Detection Payload* to remind the user to arrange the equipment usage or check the grazing status of the livestock in time.

5.2.5 Active State Count

The product's activity can be detected by the product's built-in three-axis sensor.

Whenever the state of the LW001-BG PRO changes stationary to motion, the activity count will be increased by one. One or more moves within *Activity State Timeout* will be judged as one activity, and *Activity State Timeout* can be set according to different application scenarios.

Each *Heartbeat Payload* will contain the number of activities between the time the last *Heartbeat Payload* was reported and the time the current heartbeat packet was sent.

5.2.6 Tamper Alarm

The LW001-BG PRO has tamper alarm function.

When LW001-BG PRO is abnormally removed from the installation location, the tamper button will pop up, LW001-BG PRO will flash the alarm alert and send the *Tamper Alarm Payload* to the server to remind the user. Users can use *Downlink for Position* function to request for location information to secure the tracked assets.

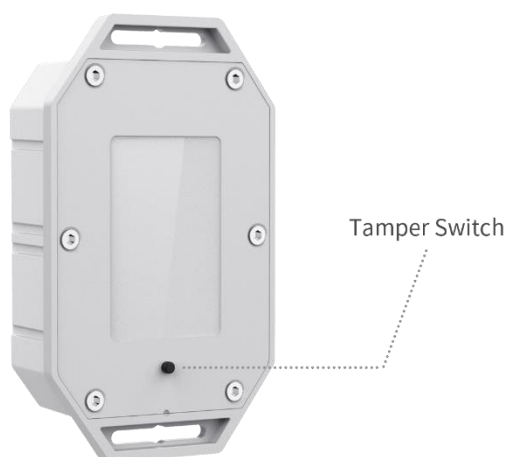

5.3 Positioning Strategies

The device can set the corresponding positioning strategy in periodic mode, timing mode, and motion mode. In addition, *Downlink for Position* can also set a separate positioning strategy, which can be different from the positioning strategy in the working mode.

LW001-BG PRO has the following main positioning strategies:

- Only WiFi: Only WIFI scans are used for position determination.
- Only Bluetooth: Only Bluetooth scans are used for position determination.
- Only GPS: Only GPS is used for position determination.
- WiFi+GPS: WIFI then GPS if WIFI fails in one geolocation cycle.
- Bluetooth+GPS: Bluetooth then GPS if Bluetooth fails in one geolocation cycle.
- WiFi+BLE: WIFI then Bluetooth if WIFI fails in one geolocation cycle.
- WiFi+BLE+GPS: Use WIFI, Bluetooth, GPS for positioning in turn (switch to the next type of positioning after one type of positioning fails)

5.3.1 WiFi Fix

LW001-BG PRO obtains the surrounding hotspot information through WIFI scanning function and reports the MAC address of device and the corresponding RSSI to the server through LoRa, and the application server goes to calculate the location, the accuracy of positioning depends on the actual deployment of the customer and the calculation of the location algorithm.

The success of WIFI positioning depends on the WIFI location scan time and the number of BSSIDs. the time of WIFI scan and the number of BSSIDs thresholds can be set by the user.

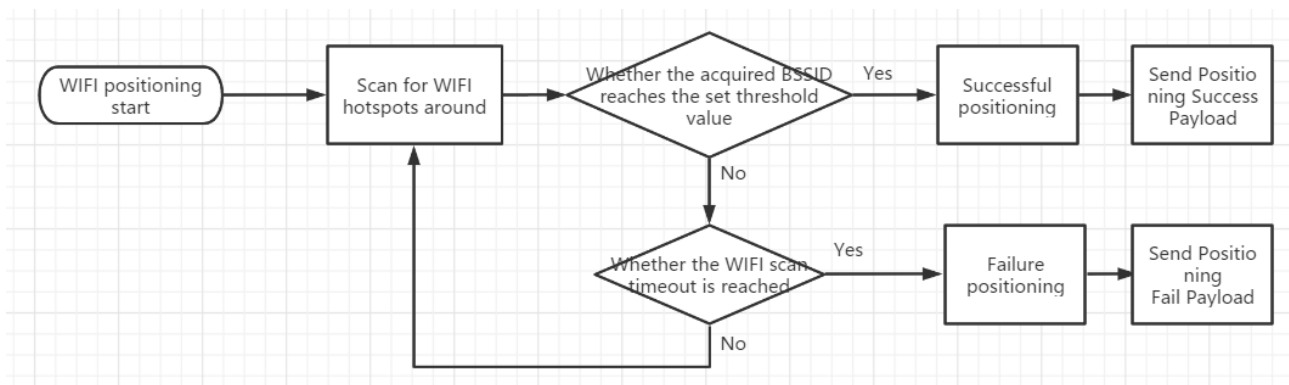

5.3.2 Bluetooth Fix

LW001-BG PRO obtains the broadcast information of surrounding Bluetooth devices through Bluetooth scanning function, and reports the information (MAC address and RSSI) of Bluetooth devices that meet the conditions of Bluetooth filtering to the server through LoRa, and the application server goes to calculate the location, the accuracy of positioning depends on the actual deployment of the customer and the calculation of the location algorithm.

The following BLE Beacon types are supported for scanning:

- iBeacon (Apple)
- Eddystone (Google)
- Unknown (For example, a manufacturer-defined format)

The success of Bluetooth positioning depends on the Bluetooth location scan time and Bluetooth device count threshold. The Bluetooth scan time and Bluetooth device count thresholds can be set by the user.

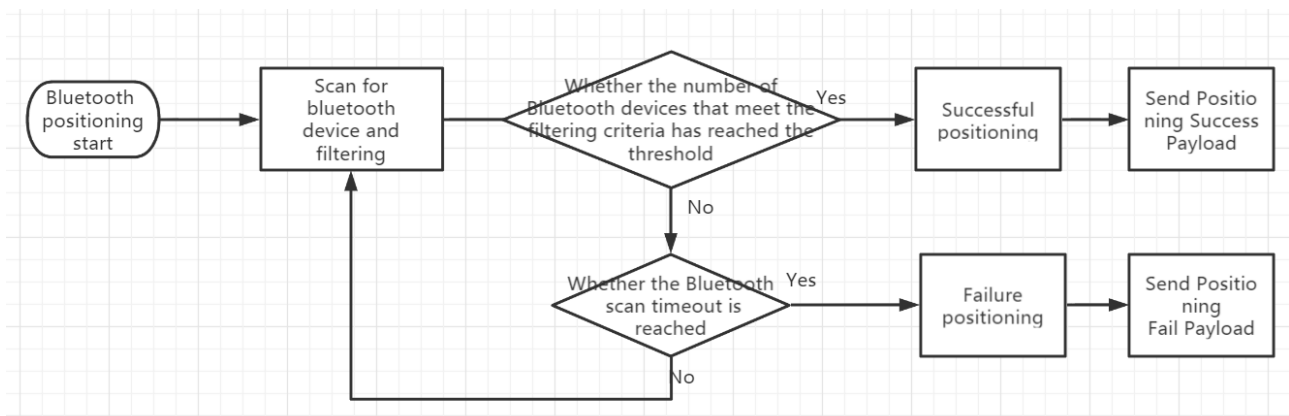

5.3.2.1 Filtering Rules

Because there are many Bluetooth devices in our lives, setting reasonable filtering rules can help remove interference from other Bluetooth devices to the Bluetooth positioning system.

The following is the specific description of Filtering Rules:

- ① There are two sets of filter conditions, one is Filter Condition A, and other one is Filter Condition B. Each filter condition has a separate switch setting, which can be arbitrarily switched on or off.
- ② When both of Filter Condition A and Filter Condition B are switched on, the relationship between two sets of filter conditions can be set as AND or OR.

AND: Beacon information is stored and reported only when the data meets both Filter Condition A and Filter Condition B.

OR: Beacon information is stored and reported when the beacon data meets either filter condition A or filter condition B.

If only one condition is opening, the data that meets this filter condition will be saved and uploaded.

- ③ There are seven filter items in each set of filter conditions, which are RSSI Filter, MAC Address Filter, UUID Filter, ADV Name Filter, Major Filter, Minor Filter and Raw Data Filter. Only if these seven filter items are met at the same time can this filter condition be considered to be met.

Each filter item can be set to off, positive filter and reverse filter.

Off: Regardless of this filter item.

Positive filter: If the device being scanned matches the content of this filter item, it is considered to meet the filter item.

Reverse filter: If the device being scanned does not match the contents of this filter item, it is considered to meet the filter item.

5.3.3 GPS Fix

LW00BG PRO obtains the corresponding location information via satellite to determine the location of the product.

This product adopts high precision GPS positioning module and supports cold start, warm start and hot start mechanism.

When the device successfully obtains the location information, it will enter the hibernation mode, and the location information will be reported at the reporting time point, and the reporting content will include the successful positioning time point, so that the location trajectory analysis can be performed.

Note: *There are many advanced parameters to set here, which can be viewed in the APP guide. If you are not familiar with these parameters, it is recommended to just use the default values.*

5.3.4 Offline Fix

The user can choose to locate the device even if it is not successfully connected to the network, and save the location information in the device, and the customer can later read the local data via Bluetooth or LoRa downlink to restore the historical location information of that time period

5.4 Bluetooth Broadcast Capabilities

LW001-BG PRO has two Bluetooth broadcast modes: Beacon mode and Configuration mode, which can be switched by users.

5.4.1 Beacon Mode

The LW001-BG PRO will always broadcast Bluetooth information in Beacon mode, and users can use the LW001-BG PRO as a beacon device to do Bluetooth positioning and other application development.

When the device is in Beacon mode, the user can choose to leave the device in a connectable or non-connectable state, considering that it prevents strangers from being able to establish a Bluetooth connection with the LW001-BG PRO at will.

Connectable state: The device is always available to be connected by the host.

Non-connectable state: Bluetooth broadcasting will always be going on, but only within 3 minutes after the product is turned on, the user can use the host device to establish a Bluetooth connection with the LW001-BG PRO.

Note: When the device is in beacon mode, considering the performance of both broadcasting and scanning cannot be taken into account, the Bluetooth positioning function will not work properly, and if Bluetooth positioning is performed at this time, it will be directly judged as failure.

5.4.2 Configuration Mode

When Bluetooth broadcast is in configuration mode, the device can make a Bluetooth broadcast and can be connected in the following two cases.

1. Within the first N minutes after the device is turned back on.
2. LoRaWAN server sends LoRa command to turn on Bluetooth broadcast for N minutes.

Note: N is the configuration mode broadcast timeout time, can be configured by the user. If the device is successfully connected and then disconnected, the broadcast timeout will be refreshed, and the user can choose to establish Bluetooth connection with the device again within this time.

5.4.3 Bluetooth Broadcast Contents

The broadcast contents of LW001-BG PRO are divided into advertise packet and response packet. The following is an example of the broadcast content:



LW001-BG-FA22 (iBeacon) CONNECT ⋮

F4:40:78:13:FA:22
NOT BONDED ▲ -47 dBm ↔ 110 ms

Device type: LE only
Advertising type: Legacy
Flags: GeneralDiscoverable, BrEdrNotSupported

Beacon:
Company: Apple, Inc. <0x004C>
Type: Beacon <0x02>
Length of data: 21 bytes
UUID:
e2c56db5-dffb-48d2-b060-d0f5a71096e0
Major: 0
Minor: 0
RSSI at 1m: -65 dBm
[Service Data](#): UUID: 0xAA02 Data:
0x0000200E46F4407813FA22
Complete Local Name: LW001-BG-FA22

CLONE RAW MORE

Raw data:

0x0201061AFF4C000215E2C56DB5DFFB
 48D2B060D0F5A71096E000000000BF0E
 1602AA0000200E46F4407813FA220E094
 C573030312D42472D46413232

Details:

LEN.	TYPE	VALUE
2	0x01	0x06
26	0xFF	0x4C000215E2C56DB5DFFB48D2B060D0F5A71096E000000000BF
14	0x16	0x02AA0000200E46F4407813FA22
14	0x09	0x4C573030312D42472D46413232

LEN. - length of EIR packet (Type + Data) in bytes.
TYPE - the data type as in <https://www.bluetooth.org/en-us/specification/assigned-numbers/generic-access-profile>

OK

5.4.3.1 Advertise Packet

Advertise packet is in standard iBeacon frame format.

LEN	TYPE	VALUE
2	0x01	0x06
26	0xFF	0x4C 00 02 15 E2 C5 6D B5 DF FB 48 D2 B0 60 D0 F5 A7 10 96 E0 00 00 00 00 BF

- UUID: E2C56DB5-DFFB-48D2-B060-D0F5A71096E0
- Major:0 (0x00 00)
- Minor:0 (0x00 00)
- RSSI@1m: -65dBm (0xBF)

5.4.3.1 Response Packet

LEN	TYPE	VALUE
14	0x16	0x02 AA 00 00 20 0E 46 F4 40 78 13 FA 22
14	0x09	0x4C 57 30 30 31 2D 42 47 2D 46 41 32 32

- Service: LW001-BG (0x AA 02)
- Bluetooth TX Power: 0 dBm (0x00)
- Device Status: 0x20 (0x20 = 0010 0000)
 - Bit5(1 means that the device moved since the last payload; 0 means that the device didn't move since the last payload)
 - Bit4(1 means that the device is in idle status; 0 means that the device isn't in idle status)
 - Bit3(1 means that the device was abnormally disassembled; 0 means that the device wasn't abnormally disassembled)

- Bit2(1 means low power; 0 means normal)
- Bit1(1 means that the device is in motion mode;0 means that the device is in timing mode)
- Bit0(1 means that the device is in periodic mode;0 means that the device is in standby mode)
- Battery Voltage: 3.654V (0x0E 46)
- Device ADV Name: LW001-BG-FA22 (0x4C 57 30 30 34 2D 43 54)

5.5 LoRaWAN Capabilities

The data of LW001-BG PRO will be transmitted via LoRa and LW001-BG PRO is based on the standard LoRaWAN protocol V1.0.3.

LW001-BG PRO is compatible with mainstream gateways and mainstream servers (TTN, SENET, LORA IOT, etc.) in the market.

DeviceTimeReq MAC Command: LW001-BG PRO supports the DeviceTime feature, which enables users to periodically time their devices to avoid time offset. The *Time Sync Interval* of the MKLoRa APP is the Device Time MAC Command interval. (Please refer to [LW001-BG PRO APP Guide](#))

5.5.1 Timed Reconnect

To ensure a smooth network after a long time, users can set up periodic reconnection to the LoRaWAN network. When the reconnect time point is reached, the device will send join-request.

5.5.2 LoRa Uplink Transmission Strategy

Considering the load balance of the gateway, the battery power consumption and the reliability of the messages, the LW001-BG PRO is equipped with a LoRa uplink mechanism for users to choose, so that users can select a suitable sending strategy according to different application scenarios.

5.6 3-Axis Accelerometer Capabilities

With the built-in three-axis sensor, the device can achieve *ManDown Detection*, *Vibration Detection*, *Active State Count* and motion detection in *Motion Mode*.

Depending on the application scenario, LW001-BG PRO has two different trigger conditions that apply to different functions.

Moving judgment condition (*Motion Threshold* & *Motion Duration*): If LW001-BG PRO exceeds the *Motion Threshold* and continues for a period of time (*Motion Duration*), LW001-BG PRO will be considered to have reached the moving judgment condition. Moving judgment condition is suitable for *ManDown Detection*, *Active State Count* and motion detection in *Motion Mode*.

Vibration judgment condition (*Vibration Threshold*): If LW001-BG PRO exceeds the *Vibration*

Threshold, LW001-BG PRO will be considered to have reached the vibration judgment condition. Vibration judgment condition is suitable for *Vibration Detection*.

5.7 Local Data Sync

LW001-BG PRO Built-in 4M FLASH memory chip, can support 20,000 pieces of data local storage at most. All data uploaded by the device is stored in the device.

Users can read data of the past 1 day, 7 days, 1 month, 3 months, 6 months, 1 year or custom days via Bluetooth or downlink command.

When the LoRaWAN network has problems or data loss is severe, users can quickly get the historical reporting data from the device.

5.8 Battery Performance

The LW004-CT is equipped with 3*AA non-rechargeable battery (ER14505).

According to the operating voltage requirement of each component, the total actual power available is about 6500mAH. Based on this, the endurance of the device is about 4.5 years under typical scenarios (WIFI scan for 5 seconds, Bluetooth scan for 5 seconds and GPS positioning for 3 minutes every day).

Users can use LoRa downlink commands to have the device send *Battery Consumption Payload* and calculate the approximate power consumption.

5.8.1 Low battery Alert

When LW001-BG PRO's battery level is low, its power indicator will flash every 10s and it will report *Low Power Payload* to the server as a prompt.

Notes: Low battery threshold can be to set 5% and 10%. User can also choose not to blink the LEDs and not to report the shutdown payload.

5.8.1 Shutdown message reminder

LW001-BG PRO supports sending the *shutdown payload* as a notification alert when the device is turned off. Users can choose to turn off this feature.

Note: If the battery is suddenly disconnected or pulled out, the device cannot send the *shutdown payload*.

5.9 Time Synchronization

There are four methods to sync time of LW001-BG PRO.

1. LW001-BG PRO supports the DeviceTimeReq MAC Command, which enables users to periodically time their devices to avoid time offset.
2. When the APP connect with the device success the phone system time will be sync to the device via Bluetooth.
3. Time synchronization via GPS satellite
4. RTC: LW001-BG PRO has a built-in RTC circuit. When LW001-BG PRO is completely shut down, the RTC will continue to keep the time updated in ten days, then if the device is powered on in these ten days, the RTC will immediately synchronize the time to LW001-BG PRO.

5.10 Default Power Status

When the power of LW001-BG PRO is heavily depleted, there may be a situation where the user needs to replace the battery. Based on this, the user can choose whether to automatically turn on the power after replacing the battery and keep the previous working mode.

There are two options: “OFF” and “Revert to last mode”.

- OFF: Configure LW001-BG PRO to turn off, after the battery is replaced.
- Revert to last mode: Configure LW001-BG PRO to return to last working mode it was in, after the battery is replaced.

5.11 Configuration Tool

The device can use MKLoRa app developed by Moko for quick OTA upgrades and parameter configuration. About the detail of MKLoRa, pls refer to [LW001-BG PRO APP Guide](#).

6 Uplink Payload

Each payload is composed by:

- A common header
- A specific data part

6.1 Common payload header

	Common header			Data
Byte Index	Byte 0	Byte 1	Byte 2	Variable
Content	Device Status	Temperature	ACK & Battery voltage	Information

Device Status:

Bit Index	Content
-----------	---------

Bit 0~1	Operation mode: 00 -- Standby mode 01 -- Periodic mode 10 -- Timing mode 11 -- Motion mode
Bit 2	Battery level: 0 -- Normal; 1 -- Low battery
Bit 3	Tamper alarm: 0 -- Not triggered; 1 -- Triggered
Bit 4	Man Down status: 0 -- Not in idle; 1 -- In idle
Bit 5	Whether the tracker is in motion state since the last payload is sent
Bit 6	Positioning Type: (Only available for <i>Location Payload</i>) 0 -- Normal; 1 -- Downlink for position

Temperature:

Temperature measured in the device, it is the temperature of MCU, expressed in degree Celsius. It is a signed number.

Encoder rule: Convert to decimal, if the value > 128, then minus 256.

Example 1: The original data of payload is 1C, the temperature is 28°C.

Example 2: The original data of payload is E6, the temperature is -26°C.

ACK& Battery voltage:

Bit Index	Content
Bit 0~3	ACK: Downlink frame count, Counting will start again from 0 when it exceeds 15.
Bit 4~7	Battery voltage: Encoder rule: $2.2V + 100mV * value$; if the value is 1000(In binary), the voltage is 3.0V($2.2V + 100mV * 8$); If the value is 1010(In binary), the voltage is 3.2V($2.2V + 100mV * 10$)

6.2 Heartbeat Payload

Heartbeat Payload will be sent in Port 1.

Byte Index	Common header		Data	
	Byte 0~2	Byte 3	Byte 4	Byte 5~8
Content	Common payload header	Reason for last device reboot	FW Version	Number of Active State Counts since the last heartbeat payload.

Reason for last device reboot:

00 -- Restart after power failure

01 -- Bluetooth command request

02 -- LoRaWAN command request

03 -- Power on after normal power off

FW version: Firmware version of the device,

Bit Index	Content
Bit 6~7	Major version number: 01 means V 1.X.X
Bit 4~5	Sub-version number: 02 means V X.2.X
Bit 0~3	Patch:0101 means V X.X.5

Example 1: The FW version is 0x43, it means that the FW version is V1.0.3

Number of Active State Counts since the last heartbeat payload: Convert to decimal directly.

6.3 Location Payload

Depending on whether the positioning process is successful or not, there are two types location payloads: Location Fixed Payload and Location Failure Payload

6.3.1 Location Fixed Payload

Location Fixed Payload will be sent in Port 2.

	Common header	Data				
Byte Index	Byte 0~2	Byte 3	Byte 4~10	Byte 11	Byte 12	Byte 13~XX
Content	Common payload header	Positioning success type	Timestamp	Time zone	The length of location data	Location fixed data

Positioning success type:

00 -- WIFI positioning success

01 -- Bluetooth positioning success

02 -- GPS positioning success

Timestamp: This is the time when the positioning process succeeded, and it is possible that the location was successfully located before the reported point in time.

Encoder rule: Convert to decimal. Byte 2-3 represents the year; Byte 4 represents the month; Byte 5 represents the date; Byte 6 represents the hour; Byte 7 represents minute; Byte 8 represents second;

Time zone: The currently set UTC time zone.

Encoder rule: It is a signed number, convert to decimal, if the value > 128, then minus 256.

Example 1: The original data of payload is 0C, the time zone is UTC+12.

Example 2: The original data of payload is F6, the time zone is UTC-10.

Location fixed data:

If positioning success type is 00(WIFI positioning success), the location data is as below:

Location Data					
Byte 0~5	Byte 6	Byte 7~12	Byte 13
MAC address of WIFI device 1	RSSI of WIFI device 1	MAC address of WIFI device 2	RSSI of WIFI device2

The number of reported WIFI devices can be set by the customer.

If positioning success type is 01(Bluetooth positioning success), the location data is as below:

Location Data					
Byte 0~5	Byte 6	Byte 7~12	Byte 13
MAC address of Bluetooth device 1	RSSI of Bluetooth device 1	MAC address of Bluetooth device 2	RSSI of Bluetooth device 2

The number of reported Bluetooth devices can be set by the customer.

If positioning success type is 02(GPS positioning success), the location data is as below:

Location Data		
Byte 0~3	Byte 4~7	Byte 8
Latitude	Longitude	PDOP

Latitude and Longitude encoder rule: It is a signed number, if the value > 0x80 00 00 00, then minus 0x01 00 00 00 00. Then convert to decimal and divide by 1000000, the unit is degree (°).

PDOP encoder rule: Convert to decimal and divide by 10.

6.3.2 Location Failure Payload

Location Failure Payload will be sent in Port 3.

	Common header	Data		
Byte Index	Byte 0~2	Byte 3	Byte 4	Byte 5~XX
Content	Common payload header	Reasons for positioning failure	The length of location data	Location failure data

Reasons for positioning failure:

- 00 -- WIFI positioning time is not enough (the reporting interval is set too short)
- 01 -- WIFI positioning strategies timeout
- 02 -- WIFI module is not detected, the WIFI module itself works abnormally
- 03 -- Bluetooth positioning time is not enough (the reporting interval is set too short)
- 04 -- Bluetooth positioning strategies timeout
- 05 -- Bluetooth broadcasting in progress
- 06 -- GPS position time budget over
- 07 -- GPS coarse positioning timeout
- 08 -- GPS fine positioning timeout
- 09 -- GPS positioning time is not enough (the reporting interval is set too short)
- 0A -- GPS aiding positioning timeout
- 0B -- GPS cold start positioning timeout
- 0C -- Interrupted by *Downlink for Position*
- 0D -- Interrupted positioning at *start of movement* (the movement ends too quickly, resulting in not enough time to complete the positioning)
- 0E -- Interrupted positioning at *end of movement* (the movement restarted too quickly, resulting in

not enough time to complete the positioning)

Location failure data:

If it is WIFI positioning failure, the location data is as below:

Location Data					
Byte 0~5	Byte 6	Byte 7~12	Byte 13
MAC address of WIFI device 1	RSSI of WIFI device 1	MAC address of WIFI device 2	RSSI of WIFI device2

The information of the scanned WIFI devices will be reported.

RSSI encoded rule: Convert to decimal, and minus 256, the unit is dBm.

If it is Bluetooth positioning failure, the location data is as below:

Location Data					
Byte 0~5	Byte 6	Byte 7~12	Byte 13
MAC address of Bluetooth device 1	RSSI of Bluetooth device 1	MAC address of Bluetooth device 2	RSSI of Bluetooth device 2

The information of the scanned Bluetooth devices which meet filter conditions will be reported.

RSSI encoded rule: Convert to decimal, and minus 256, the unit is dBm.

If it is GPS positioning failure, the location data is as below:

Location Data				
Byte 0	Byte 1	Byte 2	Byte 3	Byte 4
PDOP of GPS positioning failure	C/N 0	C/N 1	C/N 2	C/N 3

PDOP of GPS positioning failure encoder rule: Convert to decimal and divide by 10. 0xFF means that the PDOP is unknown.

C/N 0: Carrier over noise (dBm) for the strongest signal satellite seen.

C/N 1: Carrier over noise (dBm) for the 2nd strongest signal satellite seen.

C/N 2: Carrier over noise (dBm) for the 3rd strongest signal satellite seen.

C/N 3: Carrier over noise (dBm) for the 4th strongest signal satellite seen.

6.4 Shutdown Payload

Shutdown Payload will be sent in Port 4.

	Common header	Data
Byte Index	Byte 0~2	Byte 1
Content	Common payload header	Shutdown Type

Shutdown type:

00 -- Bluetooth command to turn off the device

01 -- LoRaWAN command to turn off the device

02 -- Magnetic to turn off the device

6.5 Vibration Payload

Vibration Payload will be sent in Port 5.

	Common header	Data
Byte Index	Byte 0~2	Byte 3~4
Content	Common payload header	Number of vibrations since the last vibration payload in case of continuous vibration

Encoded rule for number of vibrations encoded rule: Convert to decimal directly.

6.6 Man Down detection Payload

Man Down detection Payload will be sent in Port 6.

	Common header	Data
Byte Index	Byte 0~2	Byte 3~4
Content	Common payload header	Total idle time: Convert to decimal, the unit is hour.

6.7 Tamper Alarm Payload

Tamper alarm Payload will be sent in Port 7.

	Common header	Data	
Byte Index	Byte 0~2	Byte 3~9	Byte 10
Content	Common payload header	Timestamp	Time zone

Timestamp: Convert to decimal. Byte 2-3 represents the year; Byte 4 represents the month; Byte 5 represents the date; Byte 6 represents the hour; Byte 7 represents minute; Byte 8 represents second;

Time zone: The currently set UTC time zone.

Encoder rule: It is a signed number, convert to decimal, if the value > 128, then minus 256.

Example 1: The original data of payload is 0C, the time zone is UTC+12.

Example 2: The original data of payload is F6, the time zone is UTC-10.

6.8 Event message payload

Event message Payload will be sent in Port 8.

	Common header	Data
Byte Index	Byte 0~2	Byte 3
Content	Common payload header	Event type

Event type:

00 -- Start of movement

- 01 -- In movement
- 02 -- End of movement
- 03 -- Uplink Payload triggered by downlink message

6.9 Battery Consumption Payload

Battery consumption Payload will be sent in Port 9.

	Common header	Data				
Byte Index	Byte 0~2	Byte 3~6	Byte 7~10	Byte 11~14	Byte 15~18	Byte 19~22
Content		GPS working time	WIFI working time	Bluetooth scan working time	Bluetooth broadcast time	LoRa working time

Encoder rule: Convert to decimal, the unit is seconds.

7 Maintenance instruction

- Do not use or store the device in dusty or dirty areas.
- Do not use or store the device in extremely hot temperatures. High temperatures may damage the device or battery.
- Do not use or store the device in extremely cold temperatures .when the device warms to its normal temperature, moisture can form inside the device and damage the device or battery.
- Do not drop ,knock, or shake the device. Rough handling would break it.
- Do not use strong chemicals or washing to clean the device.
- Do not paint the device ,paint would cause improper operation
- Do not disassemble the device casually or use the tools for maintenance without permission

Handle your device, battery and accessories with care. The suggestions above help you keep your device operational.

8 Revision History

Version	Description	Editor	Date
1.0	Initial version	Allen	2021-08-18

MOKO TECHNOLOGY LTD.

 4F,Buidling2, Guanghui Technology Park,
MinQing Rd, Longhua, Shenzhen, Guangdong, China

 Tel:86-755-23573370-829

 Support_lora@mokotechnology.com

 <https://www.mokosmart.com>

